

Instruction Manual

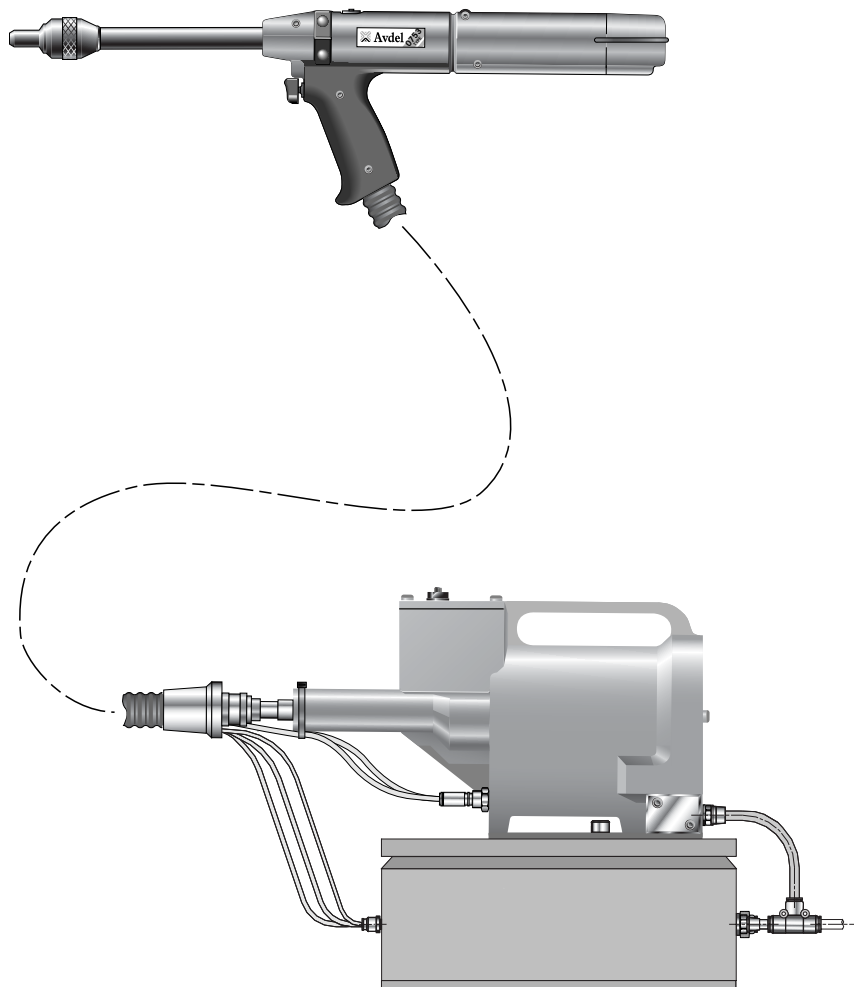

07536

Hydro-Pneumatic Power Tool

Contents

Safety Rules	4
Specifications	
Specification for 07536 Tool	5
Specification for 07531 Intensifier	5
Intent of Use	6
Tool Dimensions	7
Putting into Service	
Air Supply	8
Air Cursors	9
Loading and Re-loading the Tool	10-11
Operating Procedure	11
Servicing the Tool	
Daily / Weekly	12
Moly Lithium Grease EP 3735 Safety Data	12
Service Kit	13
Maintenance	
Air Cursor Tool, Intensifier & Control Box Assembly and Parts List	15
Dismantling 07536-02200	16-17
General Assembly and Parts List 07536-02200	18-19
Intensifier 07531-02200 - Maintenance	20
Intensifier 07531-02200 - General Assembly and Parts List	21
Priming	
Oil Details	22
Hyspin® VG 32 and AWS 32 Oil Safety Data	22
Priming Procedure	22
Fault Diagnosis	
Symptom, Possible Cause & Remedy	23

LIMITED WARRANTY

Avdel makes the limited warranty that its products will be free of defects in workmanship and materials which occur under normal operating conditions. This Limited Warranty is contingent upon: (1) the product being installed, maintained and operated in accordance with product literature and instructions, and (2) confirmation by Avdel of such defect, upon inspection and testing. Avdel makes the foregoing limited warranty for a period of twelve (12) months following Avdel's delivery of the product to the direct purchaser from Avdel. In the event of any breach of the foregoing warranty, the sole remedy shall be to return the defective Goods for replacement or refund for the purchase price at Avdel's option. THE FOREGOING EXPRESS LIMITED WARRANTY AND REMEDY ARE EXCLUSIVE AND ARE IN LIEU OF ALL OTHER WARRANTIES AND REMEDIES. ANY IMPLIED WARRANTY AS TO QUALITY, FITNESS FOR PURPOSE, OR MERCHANTABILITY ARE HEREBY SPECIFICALLY DISCLAIMED AND EXCLUDED BY AVDEL.

Avdel UK Limited policy is one of continuous product development and improvement and we reserve the right to change the specification of any product without prior notice.

Safety Rules

This instruction manual must be read with particular attention to the following safety rules, by any person installing, operating, or servicing this tool.

- 1 Do not use outside the design intent.
- 2 The Hand Tool and Intensifier have been tested as separate items and combined. They must only be used together and under no circumstances for any other purposes.
- 3 Do not use equipment with this tool/machine other than that recommended and supplied by Avdel UK Limited.
- 4 Any modification undertaken by the customer to the tool/machine, nose assemblies, accessories or any equipment supplied by Avdel UK Limited. or their representatives, shall be the customer's entire responsibility. Avdel UK Limited. will be pleased to advise upon any proposed modification.
- 5 The tool/machine must be maintained in a safe working condition at all times and examined at regular intervals for damage and function by trained competent personnel. Any dismantling procedure shall be undertaken only by personnel trained in Avdel UK Limited. procedures. Do not dismantle this tool/machine without prior reference to the maintenance instructions. Please contact Avdel UK Limited. with your training requirements.
- 6 The tool/machine shall at all times be operated in accordance with relevant Health and Safety legislation. In the U.K. the "Health and Safety at Work etc. Act 1974" applies. Any question regarding the correct operation of the tool/machine and operator safety should be directed to Avdel UK Limited.
- 7 The precautions to be observed when using this tool/machine must be explained by the customer to all operators.
- 8 Always disconnect the airline from the tool/machine inlet before attempting to adjust, fit or remove a nose assembly.
- 9 Do not operate a tool/machine that is directed towards any person(s) or the operator.
- 10 Always adopt a firm footing or a stable position before operating the tool/machine.
- 11 Ensure that vent holes do not become blocked or covered and that hoses are always in good condition.
- 12 The operating pressure shall not exceed 7 bar (100 lbf/in²).
- 13 The combination of fastener, mandrel, hole size and sheet thickness shall be in accordance with Avdel UK Limited. Specifications.
- 14 Do not operate the tool if it is not fitted with a complete nose assembly unless specifically instructed otherwise.
- 15 When using the tool, the wearing of safety glasses is required both by the operator and others in the vicinity to protect against fastener ejection, should a fastener be placed 'in air'. We recommend wearing gloves if there are sharp edges or corners on the application.
- 16 Take care to avoid entanglement of loose clothes, ties, long hair, cleaning rags etc. in the moving parts of the tool which should be kept dry and clean for best possible grip.
- 17 When carrying the tool from place to place keep hands away from the trigger/lever to avoid inadvertent startup.
- 18 Excessive contact with hydraulic oil should be avoided. To minimize the possibility of rashes, care should be taken to wash thoroughly.

I M P O R T A N T

While a small amount of wear and marking will naturally occur through normal and correct use of mandrels, they must be regularly examined for excessive wear and marking, with particular attention to the head diameter, the tail jaw gripping area of the shank or heavy pitting of the shank and any mandrel distortion. Mandrels which fail during use could forcibly exit the tool. It is the customer's responsibility to ensure that mandrels are replaced before any excessive levels of wear and always before the maximum recommended number of placings. Contact your Avdel. representative who will let you know what that figure is by measuring the broach load of your application with a calibrated test tool. These tools can also be purchased under Part Number 07900-09080, supplied with all necessary information for testing in this manual.

Specifications

Specification for 07536 Tool

Air Pressure	Minimum - Maximum	5-7 bar (70-100 lbf/in ²)
Free Air Volume Required	@ 5.1 bar /75 lbf/in ²	2.6 litres (0.09 ft ³)
Stroke	Minimum	25 mm (1 in)
Pull Force	@ 5.5 bar /80 lbf/in ²	3.89 kN (875 lbf)
Cycle time	Approximately	1 second
Noise Level	Less than	70 dB(A)
Weight	Pistol	1.2 kg (2.64 lb)
Vibration	Less than	2.5 m/s ² (8 ft/s ²)

Specification for 07531 Intensifier

Air Pressure	Minimum - Maximum	5-7 bar (70-100 lbf/in ²)
Intensification Ratio		32:1

Intent of Use

The pneumatic 07536 tool is a hand held light weight tool designed to place Avdel® speed fasteners and 1/16" Avlug® making it ideal for batch or flow-line assembly in a wide variety of applications throughout all industries.

The Hand Tool and Intensifier have been tested as separate items and combined. They must only be used together and for no other purposes. Refer to "Putting into Service" on page 8 & 9 for connection details.

Part numbers are shown to order a complete tool but no nose equipment.

The tool number for the 07536 model is 07536-02200.
See the general assemblies on pages 15-21.

Intent of Use

Tool Dimensions - 07536 Model

Part Number 07536-02100

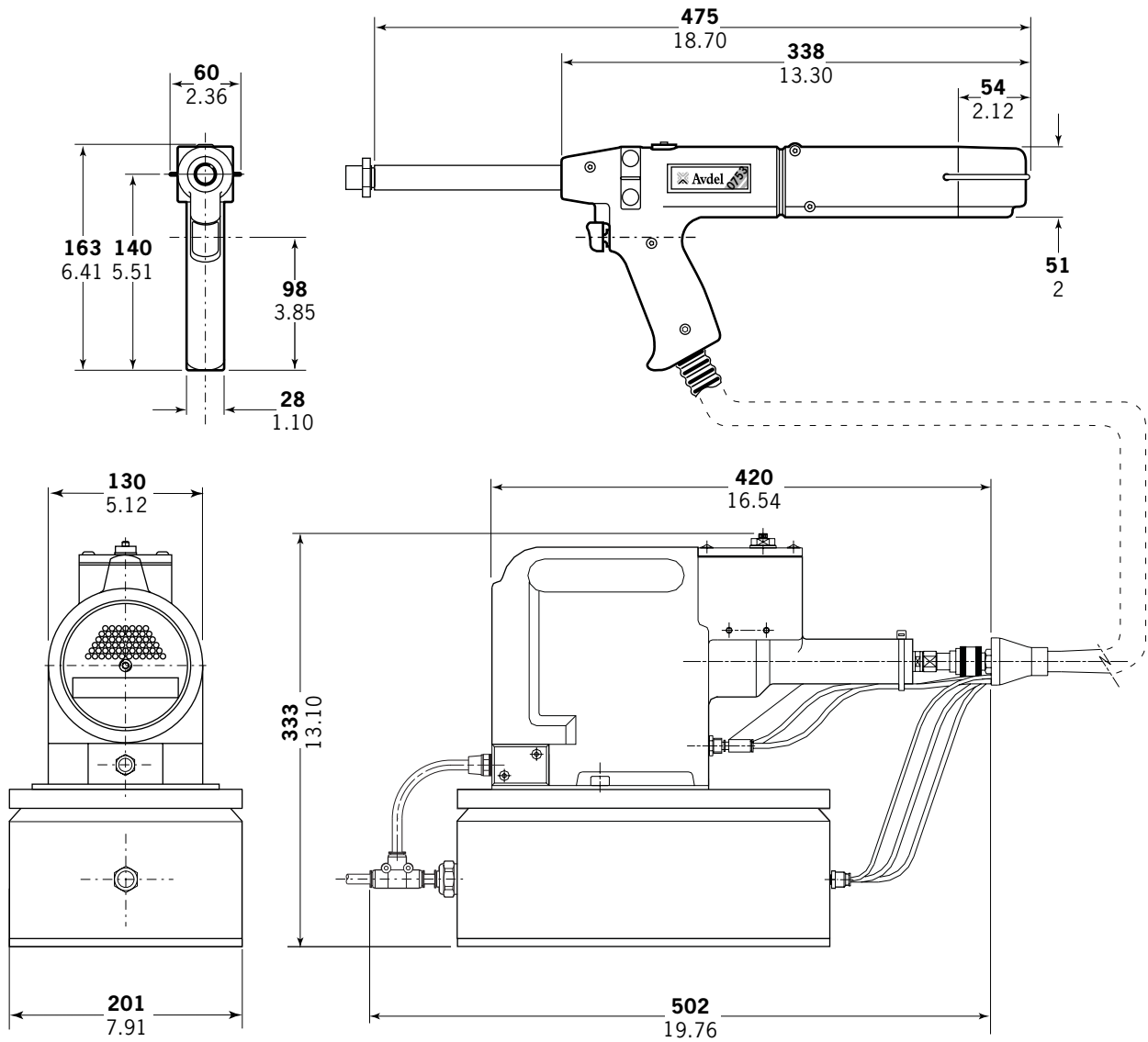

Dimensions shown in **bold** are millimetres. Other dimensions are in inches.

Putting into Service

Air Supply

All tools are operated with compressed air at an optimum pressure of 5.5 bar. We recommend the use of pressure regulators and automatic oiling/filtering systems on the main air supply. To ensure maximum tool life and minimum tool maintenance they should be fitted within 3 metres of the tool (see diagram below).

Air supply hoses should have a minimum working effective pressure rating of 150% of the maximum pressure produced in the system or 10 bar, whichever is the highest. Air hoses should be oil resistant, have an abrasion resistant exterior and should be armoured where operating conditions may result in hoses being damaged. All air supply hoses MUST have a minimum bore diameter of 6.4 millimetres or 1/4 inch.

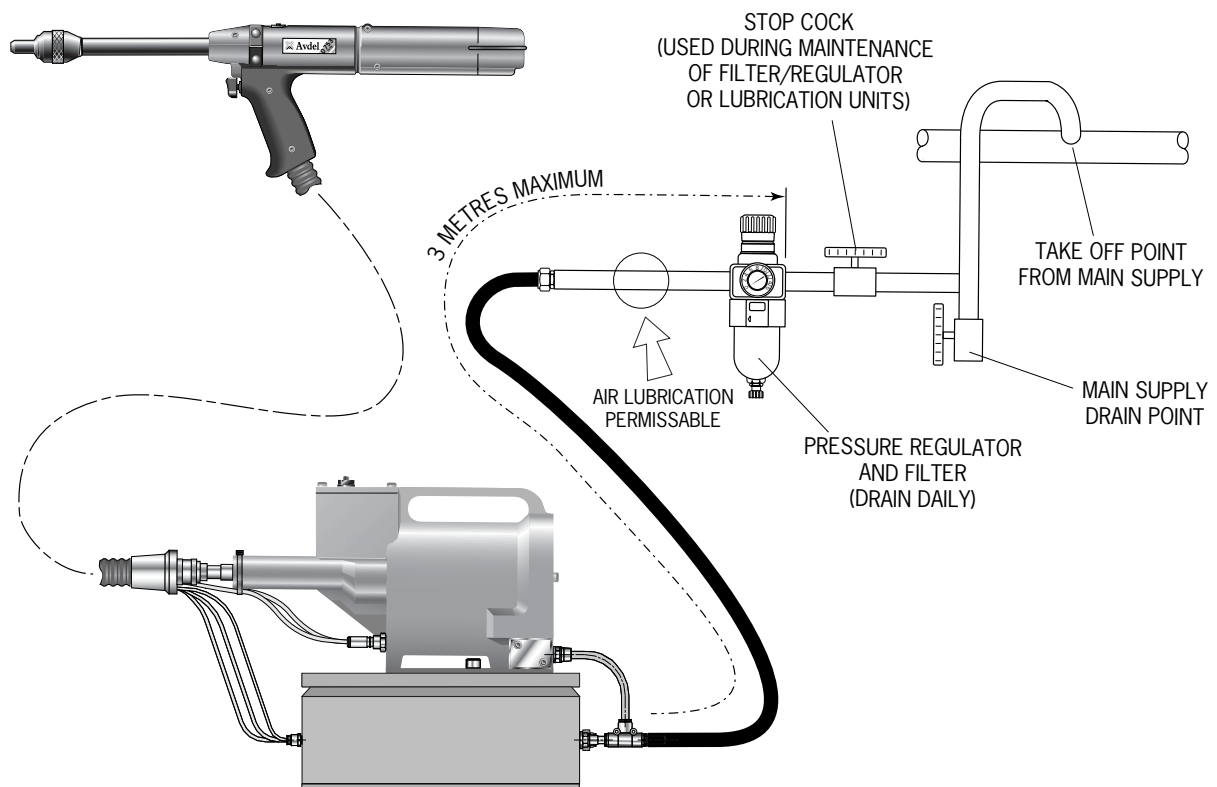

Follow the steps below when connecting the tool to the intensifier and main air supply:

- Push the end of the large hydraulic hose from the tool into the quick release connector on the end of the intensifier.
- On the front face of the intensifier (Refer to page 15):
 - Push the blue pneumatic (4mm OD) line into the reducer fitting which is located in the left hand bulkhead connector.
 - Push the black pneumatic (4mm OD) line into the plastic collet of the right hand bulkhead connector.
- On the front face of the control box (Refer to page 15):
 - Push the silver pneumatic (3mm OD) line into the reducer labelled 'Cursor' on the front face of the control box - LH side.
 - Push the green pneumatic (4mm OD) line into the reducer labelled 'Tail Jaws' on the front face of the control box - middle.
 - Push the white pneumatic (4mm OD) line into the reducer labelled 'Signal' on the front face of the control box - RH side.
- Fit a pneumatic hose between the male connector at the rear of the intensifier and main air supply.

Putting into Service

Air Cursors

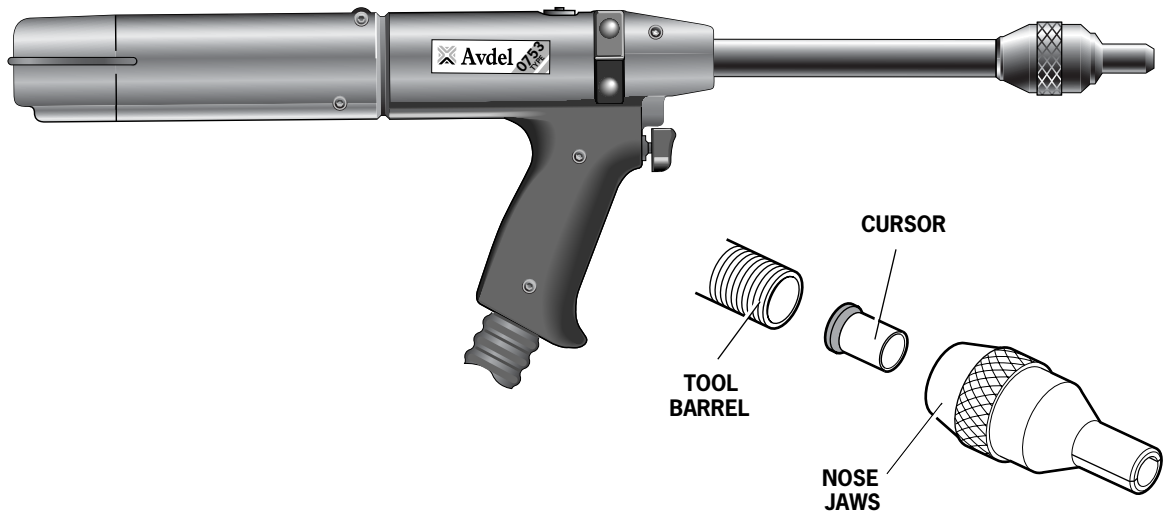

Air Cursor Selection

See separate data sheet 07900-00863 for nose assembly components.

Cursor

IMPORTANT

If fitted incorrectly, the cursor will not allow the loading of the tool and feeding of the fasteners.

While the cursor will be fitted the correct way round when the tool is supplied, we recommend that you check its orientation before fitting the nose equipment. The slightly concave end of the cursor should point towards the front of the tool as shown in the illustration.

To reverse the orientation of the cursor, follow these steps:

Extreme caution must be exercised when undertaking the following procedure. Care must be taken to avoid the barrel and protruding mandrel.

- Remove the Nose Assembly if there is one.
- Insert an empty mandrel fully into the tool.
- Close the Tail Jaws **32**, by switching on the tail jaw switch (items **18** and **19**).
- The cursor will pop out of the barrel after a short delay.
- Open the Tail Jaws **32**, by switching off the tail jaw switch (items **18** and **19**), this will release the mandrel.
- Remove the cursor from the mandrel and insert the cursor into the barrel.

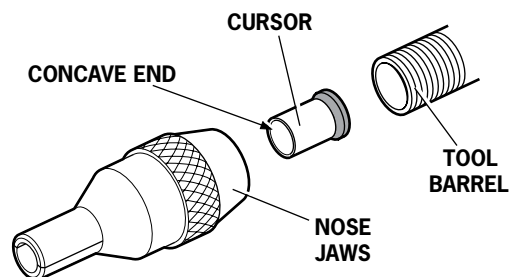

Item numbers in **bold** refer to the general assembly and parts list for the 07536-02200 Tool on pages 18-19.

Putting into Service

Loading and Reloading the Tool

IMPORTANT

The procedure for loading the tool and for fitting the nose equipment to the tool is integral.

When ordering a complete tool or system you will normally be supplied with all the nose equipment required for the fastener to be placed.

If you have been supplied with a nose jaw, mandrels and mandrel follower springs proceed with loading the tool and fitting the nose equipment as shown below.

Loading the Tool

- Connect the air supply to the tool.
- Open Tail Jaws **32** which grip the mandrel, by switching off the tail jaw switch (items **18** and **19**).
- Screw selected nose jaws onto Barrel **44** of the tool.
- * Insert a mandrel into the tail end of the fasteners through the paper pod.
- Slide the mandrel follower spring onto the mandrel ensuring correct orientation.

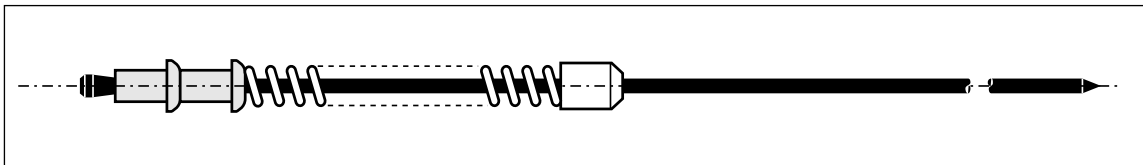

- Gripping the tail end of the mandrel, tear off the paper pod from around the fasteners.
- Open the nose jaws either by rotating the outer ring on Cam operated jaws or by pushing outwards on the jaw ends, as illustrated below left.
- Insert the previously assembled mandrel, mandrel follower spring and fasteners into the nose jaws until the first fastener to be placed is protruding from the nose jaw.
- Close the nose jaws and adjust so that the first fastener protrudes by 1.5mm - 3mm ($\frac{1}{16}$ " to $\frac{1}{8}$ "), as shown in the illustration below right.
- Close the Tail Jaws **32** to ensure the mandrel is gripped, by switching on the tail jaw switch (items **18** and **19**).

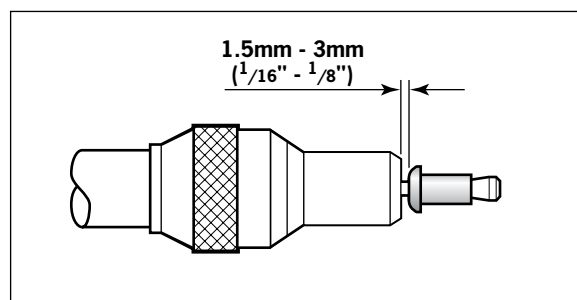
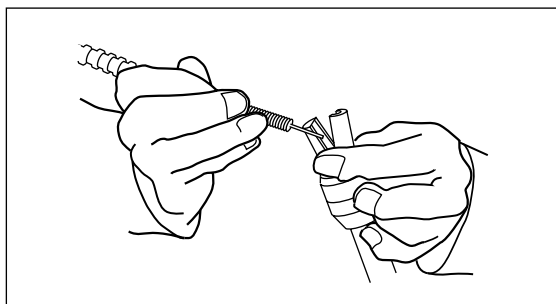

Reloading the Tool

- Open Tail Jaws **32** of tool, by switching off the tail jaws (items **18** & **19**).
- Open the nose jaws and pull the empty mandrel and mandrel follower spring out of the tool.
- Reload the tool by following the above instructions, starting at stage •*.

Item numbers in **bold** refer to the general assembly and parts list for the 07536-02200 Tool on pages 18-19.

Putting into Service

Loading and Reloading the Tool

Setting the Tool - Adjustable Nose Assemblies Only

Insert the previously assembled mandrel (see Loading the Tool •*) or the disposable mandrel against the stop within the Tail Jaw Piston Assembly **60**.

While holding the mandrel, close the Tail Jaws **32**, which grip the mandrel, by switching on the tail jaw switch (18 and 19).

Screw the lock nut onto the Barrel **44** of the tool.

Rotate the nose assembly onto the Barrel **44**.

Adjust the nose assembly so that the first fastener protrudes by 1,5mm-3mm (1/16"-1/8"), as shown in the illustration on page 10.

Tighten the lock nut against the nose assembly to prevent the nose jaw assembly from moving.

Reloading the Tool

Open the tail jaws of the tool, by switching off the tail jaw switch (**18-19**).

Open the jaws and pull the empty mandrel and follower spring out of the tool.

Insert the new mandrel against the stop within the tool, and close the Tail Jaws **32** which grip the mandrel, by switching on the tail jaw switch (**18** and **19**).

Close the Tail Jaws **32**.

Operating Procedure

IMPORTANT

You must check that the cursor orientation and the nose equipment are correct before attempting to operate the tool.

- Push the fastener, protruding from the nose jaws, fully into the application holes ensuring that the tool is held square.
- Operate the trigger without releasing - the mandrel head is pulled through the fastener, forming the fastener into the application.
- Remove the tool.
- Release the trigger. The next fastener will be automatically presented through the nose jaws, ready for placing.

Item numbers in **bold** refer to the general assembly and parts list for the 07536-02200 on pages 18-19.

Servicing the Tool

Regular servicing should be carried out and a comprehensive inspection performed annually or every 500,000 cycles, whichever is sooner.

I M P O R T A N T

**The employer is responsible for ensuring that tool maintenance instructions are given to the appropriate personnel.
The operator should not be involved in maintenance or repair of the tool unless properly trained.**

Pneumatic Control Box

I M P O R T A N T

**Under no circumstances must the pneumatic box be opened. The box is a closed item.
The internal adjustments are preset and must not be altered or tampered with.
Only Authorised Avdel personnel may dismantle this control box.**

Daily

- Daily, before use or when first putting the tool into service. Pour a few drops of clean lubricating oil into the air inlet of the intensifier if no lubricator is fitted on air supply. If the tool is in continuous use, the air hose should be disconnected from the main air supply and the tool lubricated every two to three hours.
- Check for air and oil leaks. If damaged, hoses and couplings should be replaced.
- If there is no filter on the pressure regulator, bleed the airline to clear it of accumulated dirt or water before connecting the air hose to the intensifier. If there is a filter, drain it.
- Check that the nose equipment is correct.
- Check mandrels regularly for signs of wear or damage monitoring the number of placings (read the safety instructions on page 4).

Weekly

- Conduct the full "Daily" procedures as described above.
- Remove, inspect, clean and grease the Tail Jaws (refer to "Tail Jaw Cylinder" in the "Maintenance Section" page 16).
- Check oil level in the intensifier Unit reservoir is approximately 12mm (1/2") below the transparent cover plate.

Moly Lithium Grease EP 3753 Safety Data

Grease can be ordered as a single item, the part number is shown in the service kit page 13.

First Aid

SKIN:

As the grease is completely water resistant it is best removed with an approved emulsifying skin cleaner.

INGESTION:

Ensure the individual drinks 30ml Milk of Magnesia, preferably in a cup of milk.

EYES:

Irritant but not harmful. Irrigate with water and seek medical attention.

Fire

FLASH POINT: Above 220°C.

Not classified as flammable.

Suitable extinguishing media: CO₂, Halon or water spray if applied by an experienced operator.

Environment

Scrape up for burning or disposal on approved site.

Handling

Use barrier cream or oil resistant gloves.

Storage

Away from heat and oxidising agent.

Servicing the Tool

Service Kit

For all servicing we recommend the use of the service kit (part number 07900-05300).

SERVICE KIT					
ITEM PART N°	DESCRIPTION	N° OFF	ITEM PART N°	DESCRIPTION	N° OFF
07900-00157	CIRCLIP PLIERS	1	07900-00352	SEAL REMOVAL HOOK	1
07900-00006	SPATULA	1	07900-00710	BARREL PLUG REMOVAL SPANNER	1
07900-00446	EXTRACTOR	1	07900-00725	BULLET	1
07900-00603	BARREL VICE JAWS	1	07900-00243	SCREWDRIVER	1
07900-00520	$\frac{3}{8}$ " ROD	1	07900-00717	INTENSIFIER SPANNER	1
07900-00521	$\frac{1}{4}$ " ROD	1	07900-00013	$\frac{1}{8}$ " ALLEN KEY	1
07900-00602	'O' RING ASSEMBLY BULLET	1	07900-00617	LOCTITE® MULTI-GASKET 574 50ml PACK	1
07900-00595	18mm SPANNER	1	07900-00469	2.5mm ALLEN KEY	1
07900-00434	32mm SPANNER	1	07900-00351	3mm ALLEN KEY	1
07900-00237	$\frac{3}{8}$ " x $\frac{5}{16}$ " B.S.W. SPANNER	1	07900-00224	4mm ALLEN KEY	1
07900-00012	$\frac{9}{16}$ " x $\frac{5}{8}$ " SPANNER	1	07900-00225	5mm ALLEN KEY	1
07900-00008	$\frac{7}{16}$ " x $\frac{1}{2}$ " SPANNER	1	07992-00020	80g TIN MOLY LITHIUM GREASE EP 3753	1

Note: Spanner sizes are measured 'across flats' unless otherwise specified.

Notes

Air Cursor Tool, Intensifier & Control Box Assembly

07536-02100

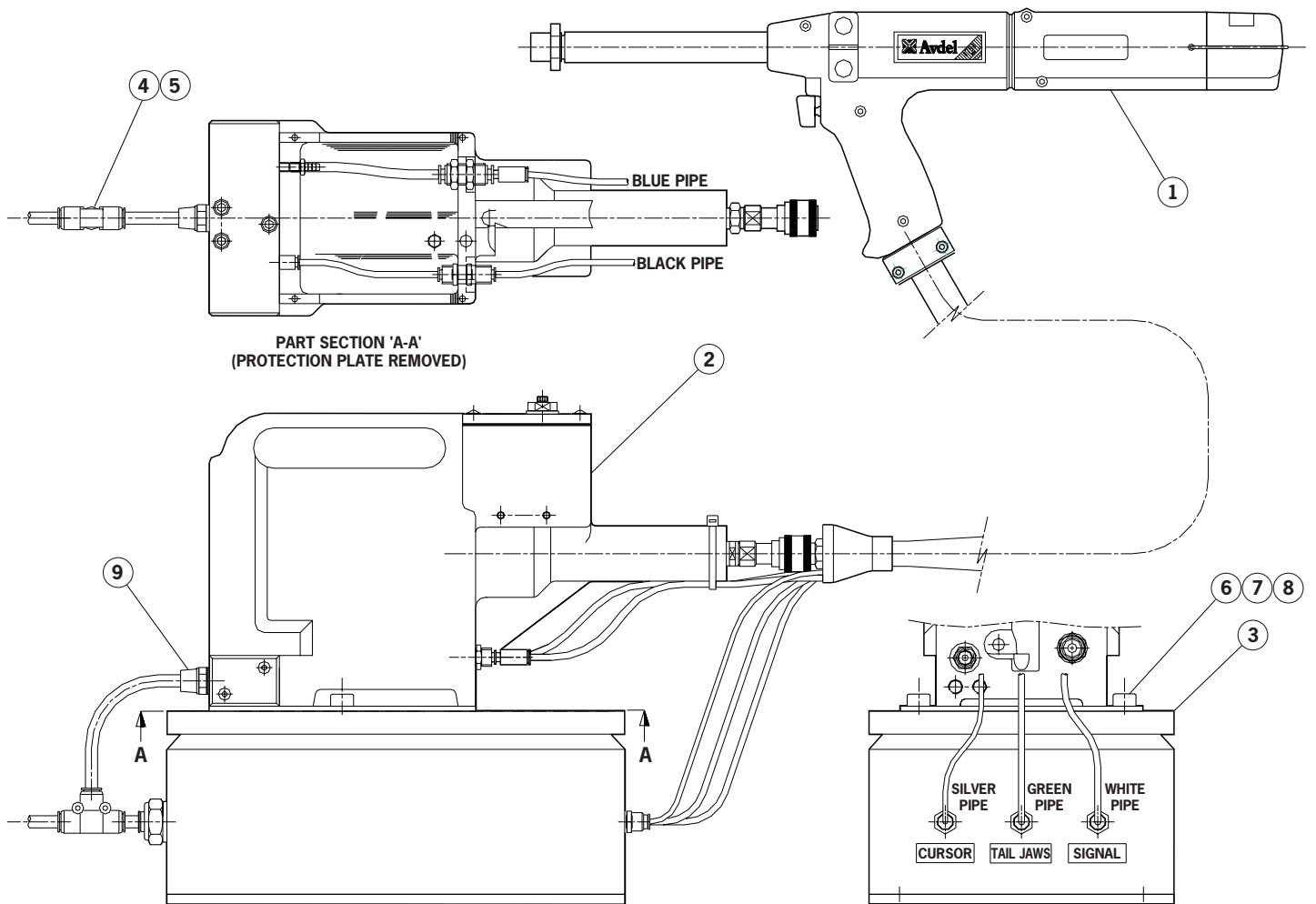

ITEM	PART No	DESCRIPTION	No OFF
1	07536-02200	AIR CURSOR HAND TOOL	1
2	07531-02200	INTENSIFIER TOOL	1
3	07007-02024	AIR CURSOR CONTROL BOX	1
4	07005-10071	T CONNECTOR	1
5	07005-10072	8 MM TUBING (2,50 m)	1
6	74405-12080	MODIFIED M8 NUTSERT	8
7	07001-00469	M8 X 15 SOCKET CAP HEAD SCREW	2
8	07002-00105	M8 WASHER	4
9	07005-01573	MALE CONNECTOR 8MM TUBE	1
10	07005-01977	MALE/FEMALE REDUCER 6MM /4MM	1

Maintenance

Every 500,000 cycles the tool should be completely dismantled and new components should be used where worn, damaged or when recommended. All 'O' rings and seals should be renewed and lubricated with Moly Lithium grease EP 3753 before assembling.

IMPORTANT

Safety Instructions appear on page 4.
The employer is responsible for ensuring that tool maintenance instructions are given to the appropriate personnel.
The operator should not be involved in maintenance or repair of the tool unless properly trained.

The airline must be disconnected before any servicing or dismantling is attempted, unless specifically instructed otherwise.

It is recommended that any dismantling operation be carried out in clean conditions.

Prior to dismantling the tool, you will need to remove the nose equipment.

For total tool servicing we advise that you proceed with the dismantling of sub-assemblies in the order shown below after having disconnected the hydraulic hose from the intensifier unit, air lines from the intensifier and control box, thus separating the pistol unit from the intensifier unit.

Dismantling 07536-02200

TAIL JAW CYLINDER

- Manually flip the retaining Clip **53** up and remove the End Cap **59**.
- Using an Allen Key*, remove one Cap Head Screw **6** ensuring that any trapped air in the tail jaw cylinder is exhausted. Remove the second Cap Head Screw **6**.
- Pull out Rear Plug **50**. **Note:** To aid extraction there is a 5mm thread on the rear face of the plug.
- Extract air tail jaw components, comprising Tail Jaw Piston Assembly **60**, Stop **52**, 'O' Ring **12** and Jaws **32**.
- Extract the remaining components, comprising of Spring **36** and Jaw Housing **42**.
- Free length of spring **36** should be 38.1mm (1.5"). Replace if necessary.
- Remove piston assembly seal 'O' Ring **11**.
- Disconnect Air Cursor Concertina Tube (Green) **49** from Elbow Connector **22**.
- Disconnect Air Cursor Concertina Tube (Silver) **38** from Barb Elbow **30**.
- Using an Allen Key*, remove all five handle moulding securing Screws **3**, **4** and all four Nuts **8** from the tool handle.
- Grip Barrel **44** in a vice using soft jaws* to avoid damage.
- Using a box spanner*, unscrew Barrel Plug **46**, preventing Barrel **44** turning by using an open ended spanner*.
- Pull the Tail Jaw Cylinder **47** from the tool.
- Remove 'O' Ring **14**, Rubbing Strip **41** and Barrel Return Spring **37**.
- Coat the face of Tail Jaws **32** with Moly Lithium grease, in contact with Jaw Housing **42**, before assembling.
- Assemble in reverse order of dismantling.

HYDRAULIC PISTON

- Remove Tail Jaw Cylinder **47** as described earlier.
- Grip Body **45** in vice using soft jaws* to avoid damage, undo Stroke Limiter **40**.
- Using an Allen Key*, loosen Screw **5** that is clamping the Switch Block **54** to the barrel **44**.
- Hold the tool firmly and pull the Barrel **44** from the Body **45** (a small quantity of hydraulic oil may be ejected from inside the head assembly).
- Remove Piston **39** carefully so as not to damage head bore.
- Remove Seal **16**.
- Seal **17** is difficult to remove without damaging, but can remain in place during cleaning (provided it is not affected by cleaning process). If however, Seal **17** requires renewing proceed as follows:
- Using spatula*, prise out Seal **17** from Body **45**, taking care not to damage body cavity and bores. The removed Seal **17** MUST be discarded.
- To replace Seal **17**, unscrew Bleed Plug Assembly **43** until inside face is level with internal bore of the Body **45**. This will provide a smooth passage for insertion of a new Seal **17** through rear of Body **45**.
- Ensure the Seal **17** is well greased and the correct way round with the open end of the seal facing the rear tail jaws.
- Complete assembly in reverse order of dismantling.

* Refers to items included in the 0753 Mkl service kit. For complete list see page 13.
Item numbers in **bold** refer to the general assemblies and parts lists on pages 18-19.

Maintenance

Dismantling 07536-02200

TRIGGER ASSEMBLY

- To dismantle/service assembly, remove covers from the tool as described earlier.
- Disconnect all air hoses from assembly, taking care not to damage them. Remove assembly.
- Using a spanner*, unscrew the Retainer **34** and remove. Take care to keep the Spring **31**.
- Prise off the 'O' Ring **10** taking care not to damage the Spindle **35** and Retainer **34** seatings.
- Clean and re-assemble using a new 'O' Ring **10**.
- Check length of Spring **31** which must be 12.7mm (0.5") free length – replace if necessary.
- Assembly in reverse order of dismantling.

TAIL JAW ON/OFF VALVE

- The unit is designed so that minimum of servicing is required during the life of the tool.
- If it is necessary to dismantle the valve, proceed as follows:
- Remove Trigger Housing **56** as described in section "Hydraulic Piston".
- Using a screwdriver*, carefully remove the Chrome Star-lock Washer **18** from Air Tail Jaw Spool **55** and discard washer.
- Extract Air Tail Jaw Spool **55** from Switch Block **54**.
- Taking care not to damage the Air Tail Jaw Spool **55**, remove the 'O' Rings **12**.
- Clean spool and refit new 'O' Rings **12** using assembly bullet* and insert into Switch Block **54**, noting its orientation.
- Fit New Chrome Star-lock Washer **18** by clamping in a soft jaw vice to prevent damage. DO NOT USE UNDUE FORCE.
- Complete assembly in reverse order of dismantling.

HANDLE & END CAP

- Clean and inspect mouldings for cracks or other damage.

CURSOR

- Clean and oil cursor assembly occasionally with a little light oil.

I M P O R T A N T

**Check the tool against daily and weekly servicing.
Priming is ALWAYS necessary after the tool has been dismantled and prior to operating.**

* Refers to items included in the 0753 Mkl service kit. For complete list see page 13.
Item numbers in **bold** refer to the general assemblies and parts lists on pages 18-19.

General Assembly of Base Tool 07536-02200

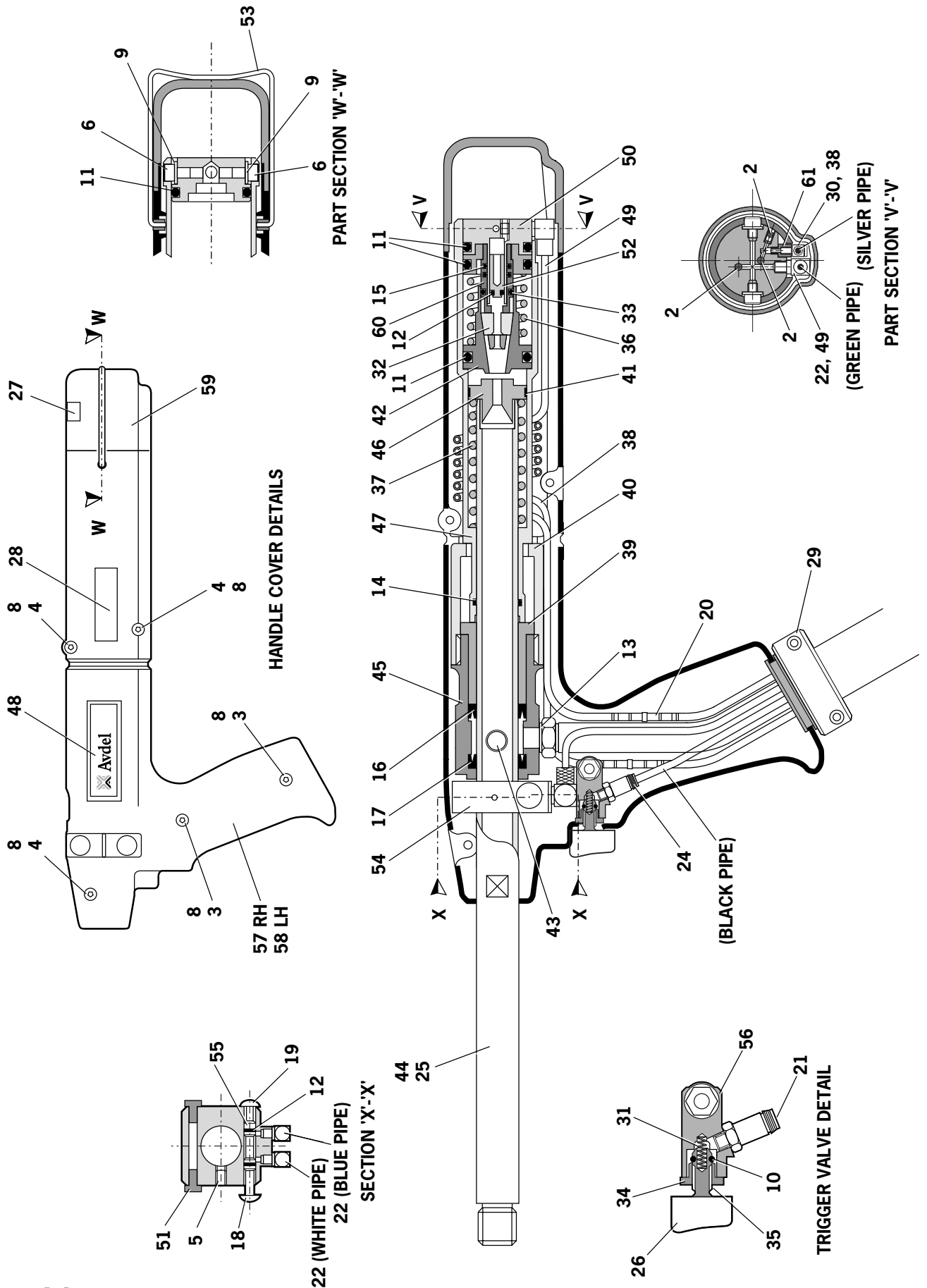

Parts List for Base Tool 07536-02200

07536-02200 PARTS LISTS									
ITEM	PART N°	DESCRIPTION	QTY	SPARES	ITEM	PART N°	DESCRIPTION	QTY	SPARES
1	07007-00392	CABLE TIE (NOT SHOWN)	1	-	36	07154-00404	SPRING	1	-
2	07001-00499	M3x5 LONG SOCKET SET SCREW	3	-	37	07490-03002	BARREL RETURN SPRING	1	-
3	07001-00262	M4x22 LONG SOCKET HEAD CAP SCREW	1	-	38	07536-02211	3MM AIR CURSOR CONCERTINA TUBE - SILVER	1	-
4	07001-00401	M4x10 LONG SOCKET HEAD CAP SCREW	4	-	39	07536-00203	PISTON	1	-
5	07001-00404	M5x6 LONG SOCKET HEAD SET SCREW	1	-	40	07530-00204	STROKE LIMITER	1	-
6	07001-00504	M4x6 LONG SOCKET HEAD CAP SCREW	2	2	41	07530-00206	RUBBING STRIP	1	1
7					42	07536-00208	JAW HOUSING	1	-
8	07002-00134	M4 HEX NUT	4	-	43	07530-00500	BLEED PLUG ASSEMBLY [ITEMS 62 TO 65] ●	1	-
9	07002-00153	M4 WASHER [PLASTIC]	2	-	44	07536-02201	BARREL	1	-
10	07003-00022	'O' RING	1	-	45	07530-02202	BODY	1	-
11	07003-00113	'O' RING	3	3	46	07530-02205	BARREL PLUG	1	-
12	07003-00121	'O' RING	3	3	47	07536-02207	TAIL JAW CYLINDER	1	-
13	07003-00142	1/8" BSP BONDED SEAL	1	1	48	07530-02210	LABEL	2	-
14	07003-00167	'O' RING	1	1	49	07536-02212	4MM AIR CURSOR CONCERTINA TUBE - GREEN	1	-
15	07003-00386	'O' RING	2	-	50	07536-02213	REAR PLUG	1	-
16	07003-00236	SEAL [DYNAMIC]	1	1	51	07530-00310	BLANKING PLUG	2	-
17	07003-00237	SEAL [STATIC]	1	-	52	07536-02214	STOP	1	-
18	07004-00058	1/8" STARLOCK WASHER CHROME	1	-	53	07530-02220	CLIP	1	-
19	07004-00059	1/8" STARLOCK WASHER BLACK	1	-	54	07530-02301	SWITCH BLOCK	1	-
20	07005-10073	3MM CONNECTOR	1	-	55	07530-02302	AIR TAIL JAW SPOOL	1	-
21	07005-01357	COLLET TYPE CONNECTOR	1	-	56	07530-02311	TRIGGER HOUSING	1	-
22	07005-01571	ELBOW CONNECTOR	3	-	57	07536-02601	HANDLE MOULDING ASSEMBLY RIGHT HAND	1	-
23	07536-02216	LOCKNUT	1	-	58	07536-02602	HANDLE MOULDING ASSEMBLY LEFT HAND	1	-
24	07005-10074	2MM CONNECTOR	1	-	59	07530-02603	END CAP	1	-
25	07007-00017	DUST CAP	1	-	60	07536-02800	TAIL JAW PISTON ASSEMBLY	1	-
26	07007-00300	TRIGGER BUTTON	1	-	61	07536-02215	FITTING ADAPTER	1	-
27	07007-01503	BOOK SYMBOL LABEL	1	-	62	07003-00142	● BONDED SEAL (NOT SHOWN)	1	1
28	07007-01504	CE MARK LABEL	1	-	63	07003-00194	● BONDED SEAL (NOT SHOWN)	1	1
29	07008-00438	FLEXIBLE HOSE ASSEMBLY	1	-	64	07001-00442	● SCREW (NOT SHOWN)	1	1
30	07005-01323	M3 BARB ELBOW	1	-	65	07530-00501	● PLUG (NOT SHOWN)	1	-
31	07125-00215	SPRING	1	-					
32	07151-00403	TAIL JAWS	1 pair	2					
33	07003-00016	'O' RING	1	-					
34	07220-00803	RETAINER	1	-					
35	07241-00208	SPINDLE	1	-					

Intensifier 07531-02200 - Maintenance

Dismantling Instructions

- When dismantling the intensifier assembly, first disconnect the air supply hose to intensifier inlet Connector **22**.
- Using an Allen Key* undo four Screws **27** and remove Protection Plate **24**.
- Disconnect the trigger hose **47** from the intensifier Valve **43** or **48** by depressing the outlet collet and withdrawing the hose.
- Remove Cover Plate **4** and Gasket **35** by removing Screws **37** and Washers **36** using Allen Key*.
- Ensure that gasket is not damaged to ensure a proper seal on assembly.
- Invert intensifier assembly and drain oil from reservoir into a suitable container.
- Remove Quick Release Connector **32** together with Connector **31** and Seals **33** with suitable spanner*.
- Remove intensifier Valve **43** or **48** by removing the fixing screws with a suitable spanner taking care to retain 'O' Ring **21** located in the Intensifier Body Casting.
- Remove Screw **19** using a suitable Allen Key* and remove Silencer Cover **16**, Foam Silencer **15**, Spacer **18** and Retaining Plate **20**.
- Pull off the 6mm Plastic Tube **41** from Vacuum Connectors **42**.
- From the base of the intensifier insert a 3mm Allen Key * through the two holes and unscrew the Vacuum Connectors **42**. Note:
 - Care must be taken as the vacuum connectors are locked and sealed in place using Loctite® 574.
 - If difficult to remove, the vacuum connectors can be drilled out using a $\frac{3}{16}$ " or 4.7mm diameter drill.
- To reassemble the Vacuum Connectors **42**, the following procedure must be followed: -
 - Soak the vacuum connectors in a suitable primer, i.e. Perma Bond A905
 - Place a drop of Loctite® 574 in the intensifier threaded hole.
 - From the base of the intensifier insert the Allen Key * through the hole. Ensure that the Allen Key * is free from Loctite® 574 before inserting into the vacuum connector.
 - Rotate the Allen Key while applying Loctite® 574 to the base of the vacuum connector.
 - Screw the Vacuum connector into the intensifier, ensuring that there is sufficient Loctite® 574 at the base of the fitting such the thread is not visible.
- Using a screwdriver, carefully remove internal Retaining Ring **14**. Clean and inspect groove for sign of damage.
- Using Extractor*, insert male threaded end into End Cover **12** and withdraw it along with intensifier Sleeve **28** and 'O' Rings **10** and **13**.
- Insert Rod* through the connector orifice at the front of the intensifier body and tap out Piston Rod **9** and Piston Assembly.
- Using a suitable Allen Key*, unscrew two Screws **25** and remove End Cover **12** from intensifier Sleeve **28**.
- Remove Seal Plug **7** with spanner*.
- Insert rod* through connector orifice at the front of the intensifier body and push out Seal Housing **5** and associated 'O' rings and lip seals.
- Remove Valve Housing Assembly **34** from the main body with a suitable spanner*. Clean by blowing through with a low-pressure air jet.
- Remove Piston Rod **9** from intensifier Air Piston **11** by gripping the first 20 mm ($\frac{3}{4}$ ") of the rod in a vice fitted with soft jaws, taking care not to damage or mark the working surface.
- Unscrew locking Nut **17** with a suitable spanner*.
- Assemble in the reverse order of dismantling, observing the following:
 - Clean all parts and renew all 'O' rings.
 - Lubricate all seals using Moly Lithium grease.
 - Valve Housing Assembly **34** must be refitted using a thread sealing adhesive.
 - Assemble the Piston Assembly using a new Nut **17**.
 - End Cover **12** must be fitted correctly inside Retaining Ring **14**. The tool must not be operated if the end cover has been omitted.

I M P O R T A N T

Priming is ALWAYS necessary after the tool has been dismantled and prior to operating.

* Refers to items included in the 0753 Mkl service kit. For complete list see page 13.
Item numbers in **bold** refer to the illustration and parts list opposite.

Intensifier 07531-02200

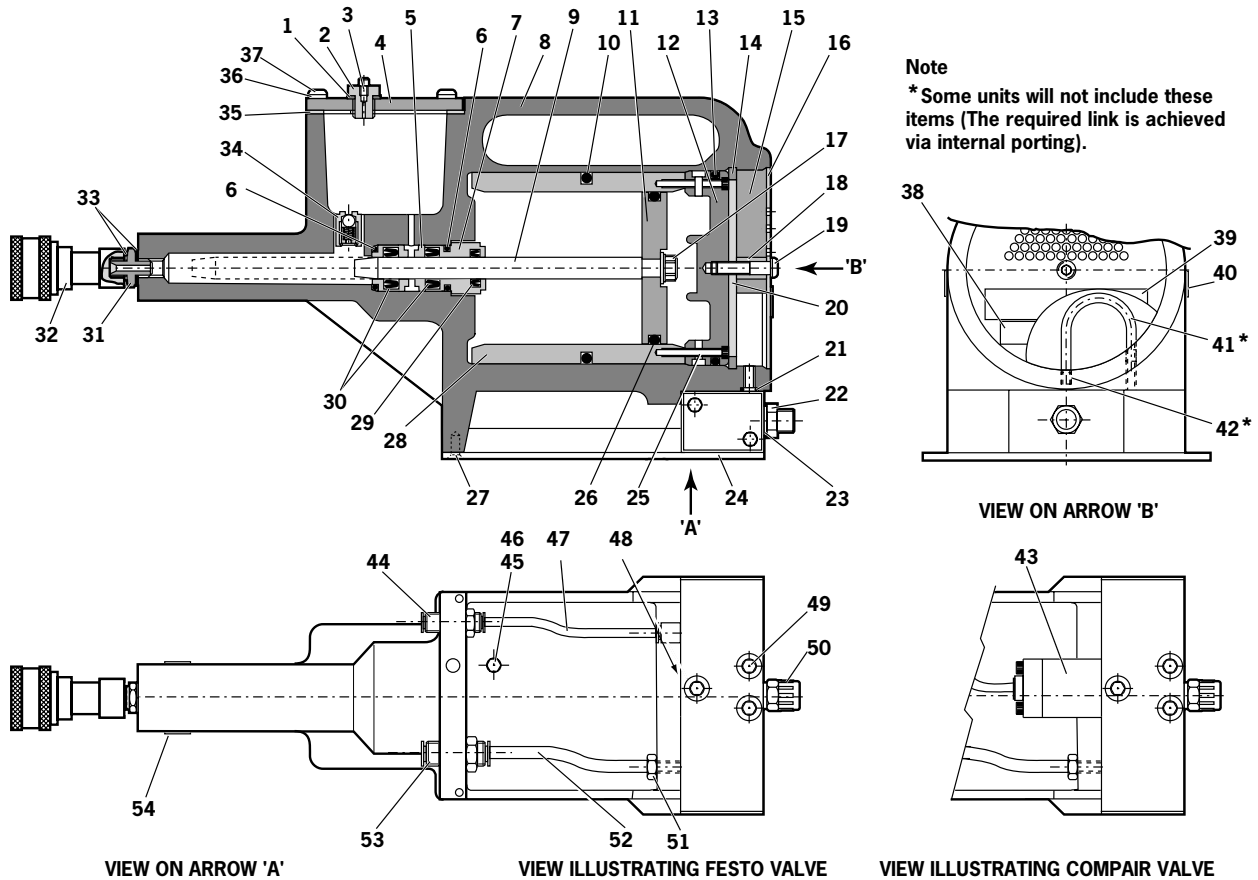

07531-02200 PARTS LIST									
ITEM	PART N°	DESCRIPTION	QTY	SPARES	ITEM	PART N°	DESCRIPTION	QTY	SPARES
1	07003-00037	SEAL	1	1	28	07531-00201	SLEEVE	1	-
2	07240-00211	FILLER SCREW	1	-	29	07003-00337	LIP SEAL	1	1
3	07001-00418	BLEED SCREW	1	1	30	07003-00336	LIP SEAL	2	2
4	07240-00210	COVER PLATE	1	-	31	07005-00406	CONNECTOR	1	-
5	71420-02006	SEAL HOUSING	1	-	32	07005-00759	QUICK RELEASE CONNECTOR	1	-
6	07003-00153	'O' RING	2	-	33	07003-00142	SEAL	2	1
7	71420-02007	SEAL PLUG	1	-	34	07240-00400	VALVE HOUSING ASSEMBLY	1	-
8	71420-02300	BODY ASSEMBLY	1	-	35	07240-00209	GASKET	1	1
9	71420-02008	PISTON ROD	1	-	36	07002-00073	WASHER	4	1
10	07003-00182	'O' RING	1	1	37	07001-00554	SCREW	4	1
11	07531-00202	AIR PISTON	1	-	38	07007-01504	LABEL	1	-
12	07531-00204	END COVER	1	-	39	07240-00217	LABEL	1	-
13	07003-00183	'O' RING	1	1	40	07531-00205	LABEL	2	-
14	07004-00069	RETAINING RING	1	1	41	07005-00596	* 6mm PLASTIC TUBE	-	-
15	07240-00213	FOAM SILENCER	1	1	42	07245-00103	* VACUUM CONNECTOR	2	-
16	07240-00214	SILENCER COVER	1	-	43	07005-00590	COMPAIR VALVE	1	1
17	07002-00017	NUT	1	1	44	07005-01431	BULKHEAD CONNECTOR	1	1
18	07240-00215	SPACER	1	-	45	07005-00668	M5 PLUG	1	-
19	07001-00417	SCREW	1	1	46	07005-00670	M5 SEALING RING	1	-
20	07240-00216	RETAINING PLATE	1	-	47	07005-01084	4mm PLASTIC TUBE (150mm)	-	-
21	*07003-00042	'O' RING	1	1	48	07005-01524	FESTO VALVE	1	-
22	07005-00041	CONNECTOR	1	-	49	07001-00176	SCREW	3	-
23	07003-00065	WASHER	1	-	50	07007-00292	1/4" BSP REDCAP	1	-
24	07240-00220	PROTECTION PLATE	1	-	51	07005-00647	CONNECTOR	1	-
25	07001-00375	SCREW	2	-	52	07005-01085	6mm PLASTIC TUBE (150mm)	-	-
26	07003-00238	'O' RING	1	1	53	07005-00855	BULKHEAD UNION	1	-
27	07001-00396	SCREW	4	-	54	07007-01503	LABEL	1	-

Priming

Priming is ALWAYS necessary after the tool has been dismantled and prior to operating. It may also be necessary to restore the full stroke after considerable use, when the stroke may be reduced and fasteners are not fully placed by one operation of the trigger.

Oil Details

The recommended oil for priming is Hyspin® VG 32 and AWS 32 available in 0.5l (part number 07992-00002) or one gallon containers (part number 07992-00006). Please see safety data below.

Hyspin® VG 32 and AWS 32 Oil Safety Data

First Aid

SKIN:

Wash thoroughly with soap and water as soon as possible. Casual contact requires no immediate attention. Short term contact requires no immediate attention.

INGESTION:

Seek medical attention immediately. DO NOT induce vomiting.

EYES:

Irrigate immediately with water for several minutes. Although NOT a primary irritant, minor irritation may occur following contact.

Fire

Suitable extinguishing media: CO₂, dry powder, foam or water fog. DO NOT use water jets.

Environment

WASTE DISPOSAL: Through authorised contractor to a licensed site. May be incinerated. Used product may be sent for reclamation.

SPILLAGE: Prevent entry into drains, sewers and water courses. Soak up with absorbent material.

Handling

Wear eye protection, impervious gloves (e.g. of PVC) and a plastic apron. Use in well ventilated area.

Storage

No special precautions.

Priming Procedure

IMPORTANT

DO NOT OPERATE THE TRIGGER WHILE THE BLEED SCREW IS REMOVED

All operations should be carried out on a clean bench, with clean hands in a clean area.

Ensure that the new oil is perfectly clean and free from air bubbles.

Care **MUST** be taken at all times, to ensure that no foreign matter enters the tool, or serious damage may result.

- Remove Screw **2** and Seal **1** from Plastic Cover plate **4** on the intensifier reservoir.
- Pour the priming oil into the reservoir until it is approximately 1/2" (12mm) from the top.
- Replace Screw **2** and Seal **1**.
- Connect the intensifier unit to the air supply. Remove screw from reservoir.
- With the 07536 pistol unit fitted to the intensifier unit and held below the level of the intensifier unit, unscrew Bleed Screw **64** from Bleed Plug Assembly **43** on the 07536 tool two turns and allow oil to flow out of the tool.
- When the oil runs freely and free of air bubbles, tighten the bleed screw.
- Top up the reservoir on the intensifier unit with priming oil.
- Cycle the tool until any air bubbles present in the oil are expelled into the oil reservoir.

Item numbers in **bold** refer to the general assemblies and parts lists pages 18-21.

Fault Diagnosis

Symptom	Possible Cause	Remedy	Page Ref
Tool will not place fastener	Low air pressure.	Increase air pressure	
	Lack of lubrication.	Lubricate tool at air inlet point	
	High broach load.	Check fastener grip and application hole size	
	Check for correct size mandrel.		
	Tail jaws switched off.	Switch on tail jaws	
	Air in hydraulic system.	See 'Priming Procedure'	22
'Mandrel Slip' - jaws will not grip mandrel	Worn or dirty tail jaws.	Clean or renew as necessary	
	' Insufficient air pressure/volume.	Increase air pressure/volume	
	' Tail jaw switch inoperable.	Replace switch	
	' Air leaks to tail jaws.	Renew 'O' rings on piston 11	
	Mandrel broken and not reaching tail jaws.	Replace mandrel	
	Fault in pneumatic control box.	Contact Avdel personnel	
Jaws will not release mandrel	Dirty tail jaws or jaw housing.	Clean and lubricate	
	Faulty tail jaw switch.	Replace 'O' rings	
	Trapped air signal	Check pneumatic lines	
	Fault in pneumatic control box	Contact Avdel personnel	
Fasteners will not feed through nose jaws	Tail jaws not switched on.	Switch on tail jaws	
	Worn tail jaws.	Renew tail jaws	
	Cursor orientation incorrect.	Refit, ensuring correct orientation	
	Incorrect cursor	Fit correct cursor	
	Incorrect nose jaws.	Fit correct nose jaws	
	Mandrel follower spring not fitted.	Fit correct mandrel follower spring	
	Mandrel follower length	Fit correct mandrel follower	
	Incorrect gap between fastener head and nose jaws when loaded.	Set gap to 1.5mm - 3mm (1/16" - 1/8") See 'Loading the Tool'	10-11
	Cursor sticking.	Clean and oil cursor	
	worn air cursor	Renew cursor	
	Incorrect mandrel follower spring fitted.	Fit correct mandrel follower spring	
	Worn or broken barrel return spring	Replace barrel return spring	
Excessive tail jaw wear	High broach load.	Check application hole size and thickness and fastener grip capability	
Feeding more than one fastener at a time	Mandrel slip.	Check as for 'Mandrel Slip', stage 2	
	Incorrect gap between fastener head and nose jaws when loaded	Set gap to 1.5mm - 3mm (1/16" - 1/8") See 'Loading the Tool' on page	10-11

Other symptoms or failures should be reported to your local Avdel authorised distributor or repair centre.

Notes

Declaration of Conformity

We, Avdel UK Limited, Watchmead Industrial Estate, Welwyn Garden City, Hertfordshire, AL7 1LY declare under our sole responsibility that the product:

Model 07536

Hand Tool Serial No.

Intensifier Serial No.

to which this declaration relates is in conformity with the following standards:

EN ISO 12100 - parts 1 & 2

BS EN ISO 8662 - part 6

BS EN ISO 3744

ISO EN 792 - part 13-2000

BS EN ISO 11202

BS EN 982

BS EN 983

following the provisions of the Machine Directive 98/37/EC



A. Seewraj - Product Engineering Manager Automation Tools

Date of issue



This box contains a power tool which is in conformity with Machines Directive 98/37/EC. The 'Declaration of Conformity' is contained within.



An Acument™ Global Technologies Company

AUSTRALIA

Acument Australia Pty Ltd.

891 Wellington Road
Rowville, Victoria 3178
Tel: +61 3 9765 6400
Fax: +61 3 9765 6445
Email: info@acument.com.au

CANADA

Avdel Canada, a Division of Acument Canada Limited.

87 Disco Road
Rexdale
Ontario M9W 1M3
Tel: +1 416 679 0622
Fax: +1 416 679 0678
Email: infoAvdel-Canada@acument.com

CHINA

Acument China Ltd.

RM 1708, 17/F., Nanyang Plaza,
57 Hung To Rd., Kwun Tong
Hong Kong
Tel: +852 2950 0631
Fax: +852 2950 0022
Email: infochina@acument.com

FRANCE

Avdel France S.A.S.

33 bis, rue des Ardennes
BP4
75921 Paris Cedex 19
Tel: +33 (0) 1 4040 8000
Fax: +33 (0) 1 4208 2450
Email: AvdelFrance@acument.com

GERMANY

Avdel Deutschland GmbH

Klusriede 24
30851 Langenhagen
Tel: +49 (0) 511 7288 0
Fax: +49 (0) 511 7288 133
Email: AvdelDeutschland@acument.com

ITALY

Avdel Italia S.r.l.

Viale Lombardia 51/53
20047 Brugherio (MI)
Tel: +39 039 289911
Fax: +39 039 2873079
Email: vendite@acument.com

JAPAN

Acument Japan Kabushiki Kaisha

Center Minami SKY,
3-1 Chigasaki-Chuo, Tsuzuki-ku,
Yokohama-city, Kanagawa Prefecture
Japan 224-0032
Tel: +81 45 947 1200
Fax: +81 45 947 1205
Email: info@acument.co.jp

SINGAPORE

Acument Asia Pacific (Pte) Ltd.

#05-03/06 Techlink
31 Kaki Bukit Road 3
Singapore, 417818
Tel: +65 6840 7431
Fax: +65 6840 7409
Email: Tlim@acument.com

SOUTH KOREA

Acument Korea Ltd.

212-4, Suyang-Ri,
Silchon-Eup, Kwangju-City,
Kyunggi-Do, Korea, 464-874
Tel: +82 31 798 6340
Fax: +82 31 798 6342
Email: info@acumentkorea.com

SPAIN

Avdel Spain S.A.

C/ Puerto de la Morcuera, 14
Poligono Industrial Prado Overa
Ctra. de Toledo, km 7,8
28919 Leganés (Madrid)
Tel: +34 (0) 91 3416767
Fax: +34 (0) 91 3416740
Email: ventas@acument.com

UNITED KINGDOM

Avdel UK Limited

Pacific House
2 Swiftfields
Watchmead Industrial Estate
Welwyn Garden City
Hertfordshire
AL7 1LY
Tel: +44 (0) 1707 292000
Fax: +44 (0) 1707 292199
Email: enquiries@acument.com

USA

Avdel USA LLC

614 NC Highway 200 South
Stanfield,
North Carolina 28163
Tel: +1 704 888-7100
Fax: +1 704 888-0258
Email: infoAvdel-USA@acument.com

© Avdel UK Limited 2007

Manual No.	Issue	Change Note No.	Date
07900-00846	AA	05/13	MAR 05
	AB	05/294	JUNE 05
	AC	06/160	OCT 06
	B	07/044	FEB 07
	B2	07/103	MAR 07
	B3	07/261	OCT 07

Avdel®, Avdel® SR, Avex®, Aviug®, Avsert®, Avtronic®, Briv®, Chobert®, Grovit®, Rivscrew® are trademarks of Avdel UK Limited.

www.avdel-global.com